

New Player on the Market for Environmental Control Systems

EBACE newcomer and traditional aerospace component manufacturer TAT Technologies first time presents customized Environmental Control Systems.

Geneva, May 19th 2008: TAT Technologies will attend the EBACE fair (stand 1942) this year for the first time in its history. Even though the company is supplying the aerospace industry for more than 30 years, it had so far never attended this trade show dedicated to business aviation.

"TAT's product spectrum is growing," says Oliver Kittan, representative of TAT Technologies in Germany. "Today we offer complete environmental control systems for aircraft (ECS), while in the past we were more a supplier of components for such systems."

Headquartered in Gadera, Israel TAT Technologies manufactures heat exchangers, climatisation and fluid control accessories as well as military and aerospace air conditioning systems for a worldwide customer base. Among TAT's renowned customers one can find companies such as Cessna, Embraer, Pilatus, Diamond, Liebherr Aerospace, Bombardier and many others.

"TAT Technologies has always presented its capabilities on military and aerospace exhibitions such as the Paris Air Show or the Eurosatory fair," says Kittan, "With our participation in the EBACE we wish to introduce our new offer: custom tailored ECS, to business and general aviation aircraft manufacturers."

In the field of environmental control systems TAT Technologies offers turnkey cabin climatisation infrastructures for business jets, turbopropelled and combustion-engine aircraft. Among others this comprises system integration into engine environments with bleed-air precoolers, combustion engine coolant cycle or exhaust heat-exchangers, compressor integration with vapor-cycle air-conditioning, mixing chambers, control-valves, ducting, gaspers and state-of the art user-friendly management and control systems.

When asked for TAT's competitive advantage Kittan replies: "as a medium-size company with lean structures TAT Technologies can offer very attractive pricing combined with a highly motivated team of experts the support and individual development flexibility of which is second to none."

TAT Technologies is a public traded company (NASDAQ: TATTF) which also offers its solutions for environmental control systems including 24 hours / 7day spare part service through its base of U.S subsidiaries.

Further information:

Oliver Kittan
Dipl.-Wirt.-Ing.

Representative
TAT Technologies
Haimendorfer Str. 57
90480 Nürnberg
Germany

T +49 911 4864 - 793

F +49 911 4864 - 797

M +49 160 963 55 983

oliver.kittan@tat-technologies.de

www.tat-technologies.de

2,762 letters

reprint free of charges - please supply copy

www.tat-technologies.de/TAT_EBACE_2008_Eng.pdf

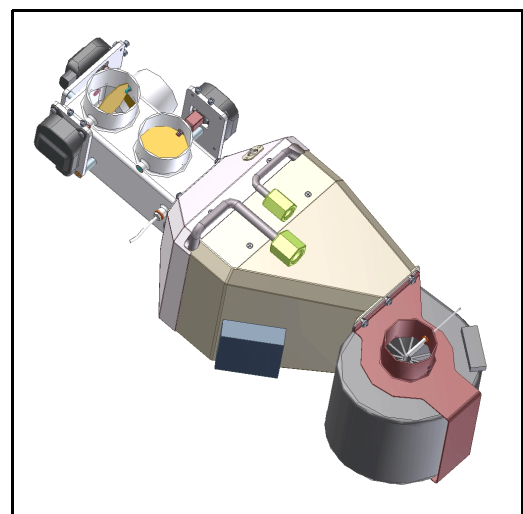

TAT custom-tailored ECS cabin climatisationair mixing chamber including vapor cycle air conditioning evaporator